

TFWB-1

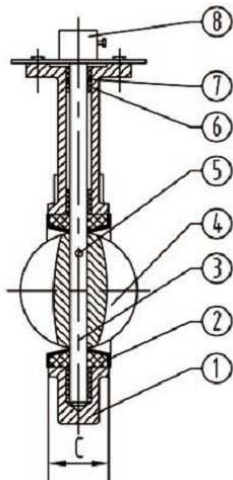
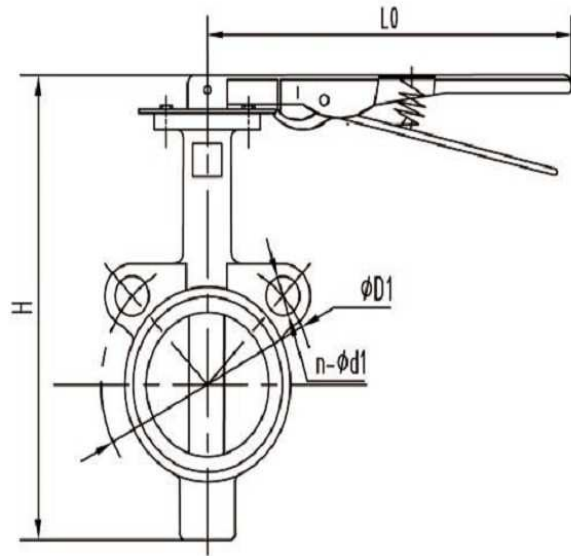

NOMINAL PRESSURE	1.6	
SHELL TEST PRESSURE	2.4	MPa
SEAL TEST PRESSURE	1.76	

STANDARD MATERIALS OF MAIN PARTS

ITEM	PART NAME	MATERIAL
1	BODY	CAST IRON
2	SEAT	EPDM
3	SHAFT	STAINLESS STEEL 416
4	DISC	DUCTILE IRON + NI
5	PIN	STAINLESS STEEL
6	BUSHING	PTFE
7	O RING	NBR
8	LEVER	

DIMENSIONS
EN1092-2 PN16

SIZE	DN	L0	H	D1	n - d1	C
DN50	Ø 50	240	247	125	4-19	42
DN65	Ø 65	240	268	145	4-19	44.7
DN80	Ø 80	240	281	160	8-19	45.2
DN100	Ø 100	240	319	180	8-19	52.1
DN125	Ø 125	260	347	210	8-19	54.4
DN150	Ø 150	260	372	240	8-23	55.8
DN200	Ø 200	360	453	295	12-23	60.6

Wafer Type Butterfly Valve			
Drawing	LJ.D	Check	XB.Z